



YMPJ

The Soundview Economic Hub

A Conceptual Reuse Plan for the
Bruckner Expressway Underpass at
Bronx River Avenue

AUGUST 2023

Current image of the Bruckner Expressway Underpass at Bronx River Avenue [future location of the Soundview Economic Hub]

Contents

1	Introduction	Page 05
2	Community Engagement	Page 11
3	Reuse Plan	Page 13
4	Financing	Page 24
5	South Bronx Context	Page 27
6	About YMPJ	Page 23
7	Moving Forward	Page 37
8	Appendix	Page 39
9	Acknowledgments	Page 46





Introduction

For eight years the Soundview, Bronx River, and Hunts Point communities have worked to reimagine and reclaim 30,000 square feet of underutilized space under the Bruckner Expressway at Bronx River Avenue. Led by Youth Ministries for Peace and Justice, Inc (YMPJ), this initiative aims to transform a large, vacant space into the Soundview Economic Hub: a community-driven space at the nexus of food systems, health, and economic development. Through this Hub, YMPJ aims to address long-standing community needs for job training opportunities, business incubation space, access to fresh, healthy foods, and intergenerational programming.

The Goals of the Soundview Economic Hub

The Soundview Economic Hub is an innovative space activation initiative which seeks to give South Bronx residents, entrepreneurs, and food growers a community-oriented space to manufacture goods and offer services that provide resources, employment, and educational opportunities. Once renovated, the space will stimulate the local economy by providing incubator spaces and classrooms for food manufacturers, vendors, and service providers, while also serving as a nexus for wholesale food and urban agriculture.

The Soundview Economic Hub aims to:

1. Support public health by fostering food sovereignty, creating a “micro-food hub” or neighborhood-based food hub that supports production, processing, and distribution.¹
2. Generate employment and job training opportunities through hands-on training and affordable incubator spaces that allow local entrepreneurs to scale.
3. Host intergenerational community events for local residents, merchants, and community groups.
4. Improve pedestrian and bicycling access in the area, connecting the Soundview, Bronx River, and Hunts Point communities.

¹Food Forward NYC: A 10-Year Food Policy Plan. Mayor’s Office of Food Policy, Feb. 2021, <https://www1.nyc.gov/assets/foodpolicy/downloads/pdf/Food-Forward-NYC.pdf>.

Development Guiding Principles

Through a series of recent focus groups, YMPJ and Hester Street discussed the future Soundview Economic Hub with local residents, community groups, service providers, and YMPJ's staff and members. The feedback provided by these stakeholders further defined the purpose and goals of the Economic Hub, shaping the following guiding principles for development.



Resourcing local merchants, vendors, and entrepreneurs

- Provide affordable spaces, relevant services, and opportunities to scale.
- Foster an ecosystem that promotes resource sharing and enables new connections.



Food and environmental justice

- Address historical food system inequities such as improving local access to the Hunts Point Markets which provide quality foods to the region while surrounding communities lack access to fresh, affordable foods.
- Build a key manufacturing, processing, and distribution hub to support the development of a regional Food Sovereignty Network serving over 200,000 residents facing food apartheid in surrounding neighborhoods.
- Anchor the establishment of a local Food Sovereignty Network that weaves distinct sites with different assets through complementary uses: the Soundview Economic Hub, Morrison Public Plaza and Open Market, the Bronx River Foodway at Concrete Plant Park, and a repurposed Amtrak Station on Westchester Avenue.



Prioritize entrepreneurs that face the most challenges and diverse cultural products

- Foster cooperative and/or community ownership.
- Target under-resourced entrepreneurs such as immigrants, youth, seniors, the formerly incarcerated, and veterans.
- Encourage emerging local markets focused on niche cultural products.

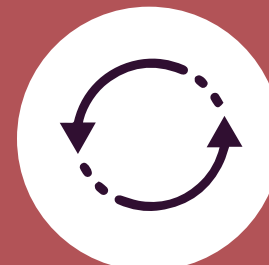

Self-sufficiency and autonomy

- Identify business models and ownership and management structures that make the Hub economically self-sustaining.
- Foster cooperative, worker-owned structures for existing and new community enterprises to foster economic democracy.
- Attract technical assistance and community investment mechanisms for community enterprises looking to scale.

“A place where different but related services are provided to the community to generate resources.”

Focus Group Participant

“A space that provides opportunities to develop personal and professional skills.”

Focus Group Participant

“A place that provides measures for both traditional and new means of resource sharing.”

Focus Group Participant

Community Engagement

YMPJ has a deep history of engaging the local community around the redevelopment of the Bruckner Expressway underpass at Bronx River Ave. Starting in 2014 with a youth design competition and later a placemaking mural initiative, YMPJ’s efforts to transform this abandoned public space into a vibrant destination have brought communities together to address long-standing needs such as economic development, food access, and intergenerational programming.

2021 Stakeholder Meetings

In the Fall of 2021, YMPJ worked in collaboration with Hester Street to build on previous engagement efforts, reconnecting with key stakeholders, and moving towards implementing the vision for the Soundview Economic Hub. Participants helped ground-truth previous feedback on key populations, desired programs and activities, partnership opportunities, and the goals of the proposed Economic Hub. What follows is a synthesis of the principles, programs and activities, and key populations identified by this group of stakeholders and local residents.

Participants emphasized that the Soundview Economic Hub should:

1. Focus on community resiliency and build community power.
2. Invoke community creativity by supporting local artists and creatives.
3. Support early-stage enterprises and provide entry level entrepreneurial opportunities.
4. Improve pedestrian and bicycling access between neighboring communities, connecting the Bronx River Greenway to Soundview Park.

Desired Programs and Activities

As part of the discussion in the stakeholder meetings, participants shared their ideas for programs and activities they would like to see offered at the Soundview Economic Hub. Participants ranked the ideas below and offered additional ideas for activities they would like to see:

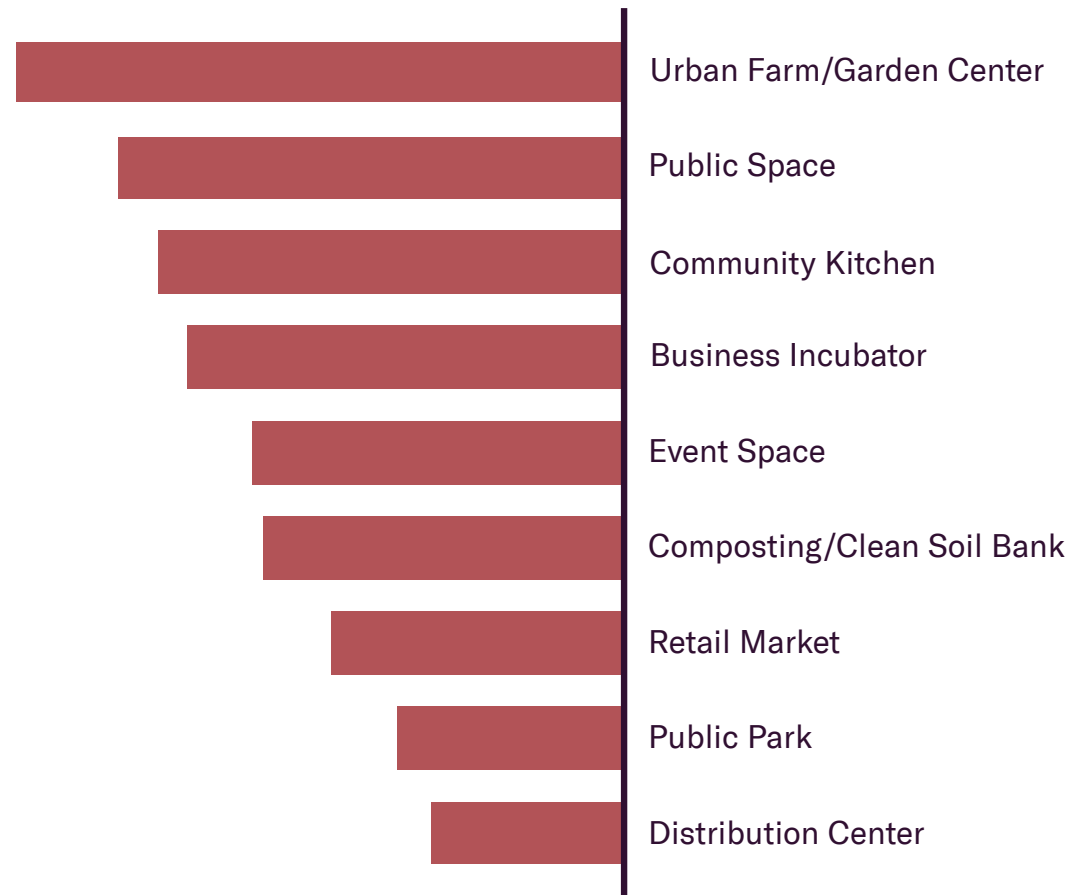

Additional Desired Activities:

- Aeroponic and Hydroponic Gardening
- Bike/Electric Vehicle Repair
- Coworking Space
- Makerspace/Workshop
- Nursery/Greenhouse that supports the Bronx River Foodway
- Skill-share Workshops/Community Learning
- Training (Electric, Plumbing, Carpentry, etc.)

Potential Clients and Tenants

Meeting participants also highlighted key clients and tenants that should be served by the Soundview Economic Hub, and those that would benefit from the proposed programs and activities. Below is the list of clients and tenants stakeholders identified.

- Community organizations
- Cyclists and greenway users
- Entrepreneurs and small local businesses
- Informal vendors and participants of the informal economy
- Justice involved/formerly incarcerated
- Local artists/cultural and traditional creatives
- New residents interested in supporting the local economy
- Residents grappling with food insecurity
- Residents faced with unemployment as well as the “underemployed”
- Teachers/students

Share Your Thoughts

1. What are some additional guiding principles that you believe should govern the Soundview Economic Hub?



2. Do you notice any missing uses or activities that you think should be included in the Soundview Economic Hub?



Share your thoughts on the questions above by scanning this QR code or visiting:

bit.ly/SoundviewEconomicHub

Reuse Plan

The proposed site is a fenced-off area consisting of four bays under the elevated structure of the Bruckner Expressway, extending from Bronx River Avenue to an area east of Colgate Avenue. Each span is approximately 75 feet long (East-West) and 100 feet wide (North-South) and totals approximately 30,000 square feet for the combined four bays. The proposed function of the site is a community-focused economic hub. It will be a semi-enclosed space with facilities, amenities, and programming that address community needs.

Site Analysis and Design Considerations

Throughout this planning effort, key stakeholders emphasized the importance of a flexible site infrastructure layout that would allow for future reconfiguration. The site analysis, design considerations and overall layout in this section represent how the site can be organized to best meet these and other community needs.

The site analysis and design considerations include:

- Site circulation and accommodations
- Mitigation of noise
- Air movement and quality
- Natural/artificial lighting and quality of light
- Utility connection points
- Visual presence and branding of the facility

Site Circulation [5-Minute Walking Radius]

Pedestrian Circulation

The current site can only be accessed via a single gate along the 10-foot-wide sidewalk on Bronx River Avenue. There are no other exit points from the current enclosed fenced area. The proposed design includes a secondary egress path and gate for safety purposes at Bronx River Avenue, a pedestrian refuge area at Close Avenue, and truck/service access to the site via the eastbound Bruckner Boulevard at the Close Avenue intersection.

LEGEND

- Residential Area
- Sidewalk
- On-Street Bike Path
- Bike Path/Greenway

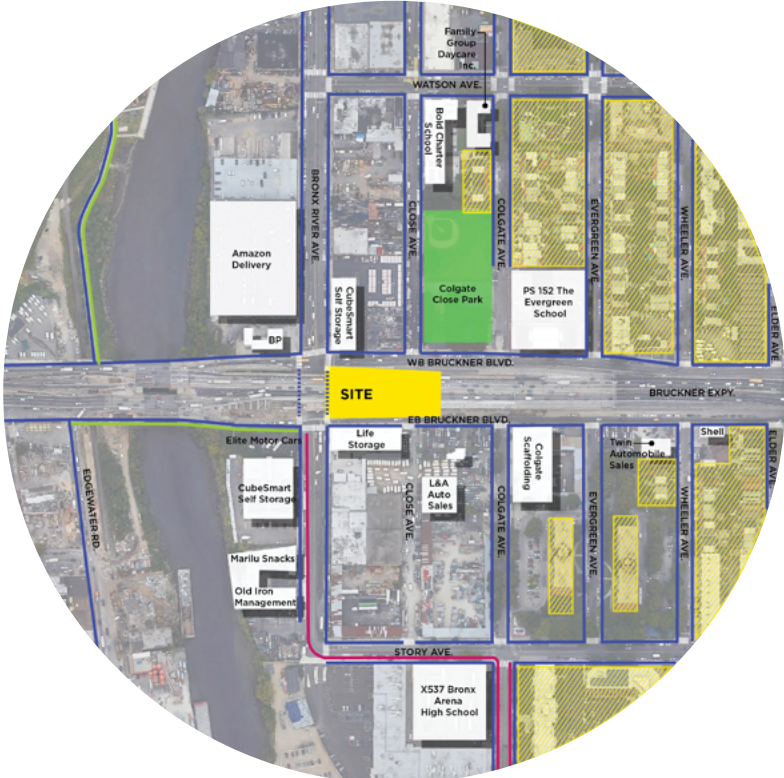

Vehicular Circulation

The site is bound by three high volume traffic surface routes: the east and west bound Bruckner Boulevard surface streets and Bronx River Avenue, all of which are directly linked to traffic flow to and from the elevated expressway. Proposed vehicular access may only be accommodated from the south side of the site, via the east bound Bruckner Boulevard. Truck/service access to the site via the east bound Bruckner Boulevard would likely only be feasible in the area of the Close Avenue intersection and would likely require flagmen accommodations.

LEGEND

- Residential Area
- AADT* ≤ 20,000
- AADT ≤ 10,000
- Local Streets
- Bus Stop

* AADT: Annual Average Daily Traffic
Source: AADT data based on NYSDOT traffic data viewer

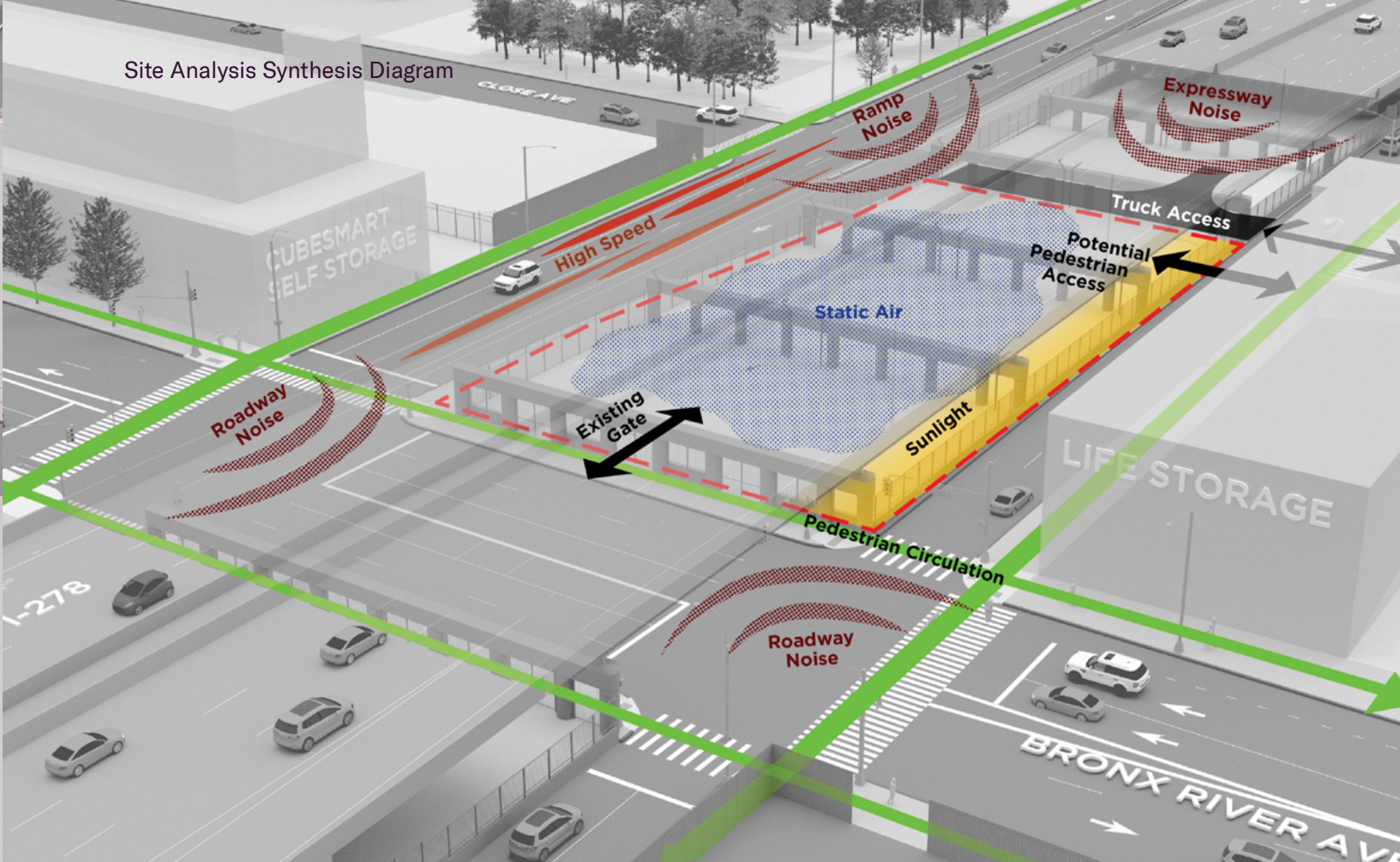
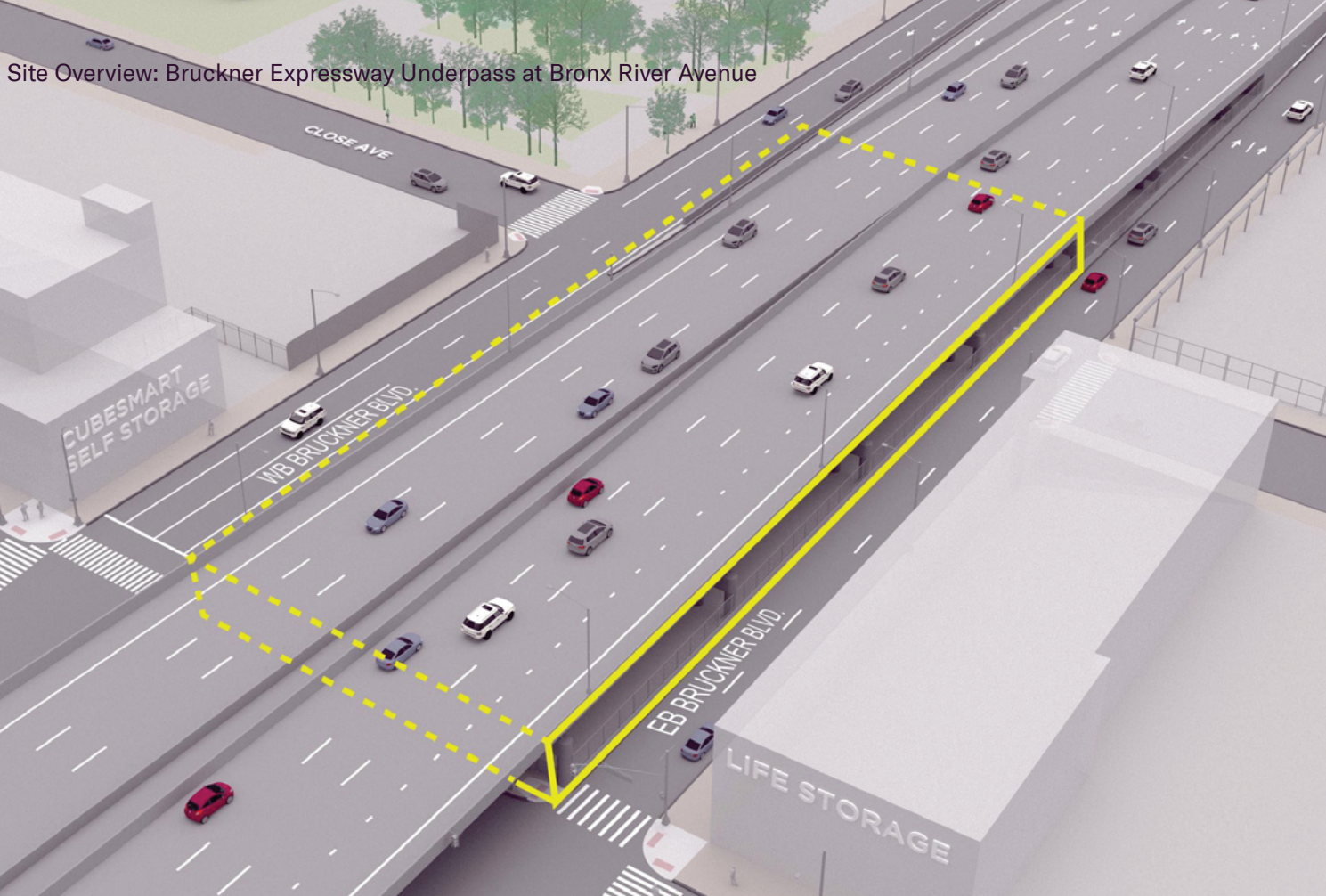
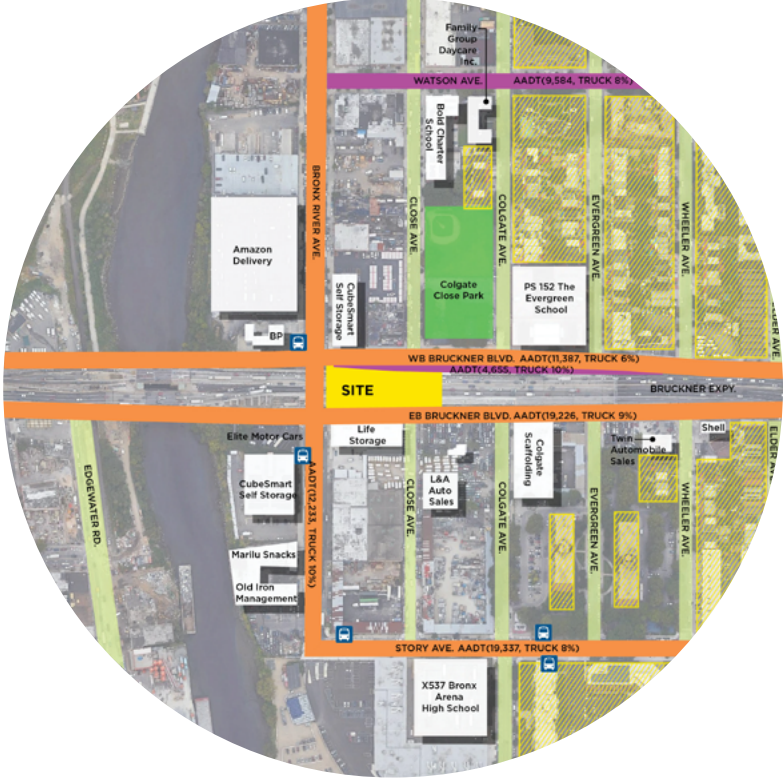

Enclosed Space Configuration

Given the location underneath the highway, enclosed modular spaces were considered to allow for indoor spaces that are insulated from weather, sound, and air quality concerns (see appendix pages 42-43 for more details). The modular units would be constructed of a lightweight and durable Structural Insulated Panel (SIP) system that will provide many benefits including lightweight materials, ease of construction and assembly, energy efficiency, and sound attenuation. This system also allows for a phased construction process and the reconfiguration of spaces as needed in the future.

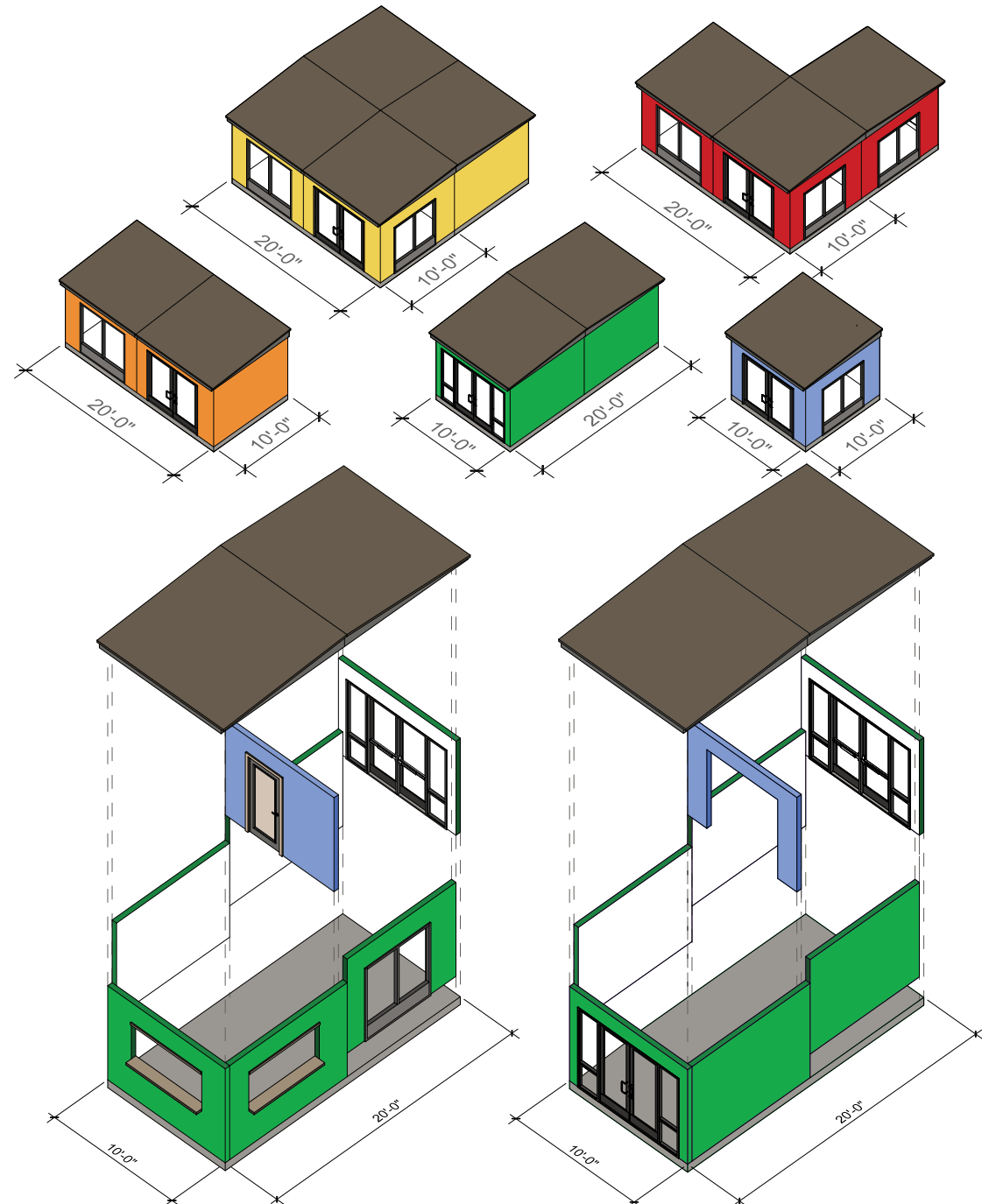

Branding and Sponsorship Opportunities

The plan proposes a flowing band of brightly lit and painted architectural metal panels, messaged signs, and graphics affixed to the overhead structure or supported by ground-mounted poles or fencing supports. Given the site's significant visibility and the high-traffic in the immediate area, this flowing band provides an opportunity to highlight the work of local artists and businesses being incubated as well as sponsors and supporters of the Economic Hub.



Street view of the future Soundview Economic Hub entrance. Signage along the fenced perimeter will provide a bold visual presence to attract visitors and showcase artists, businesses, and sponsors.

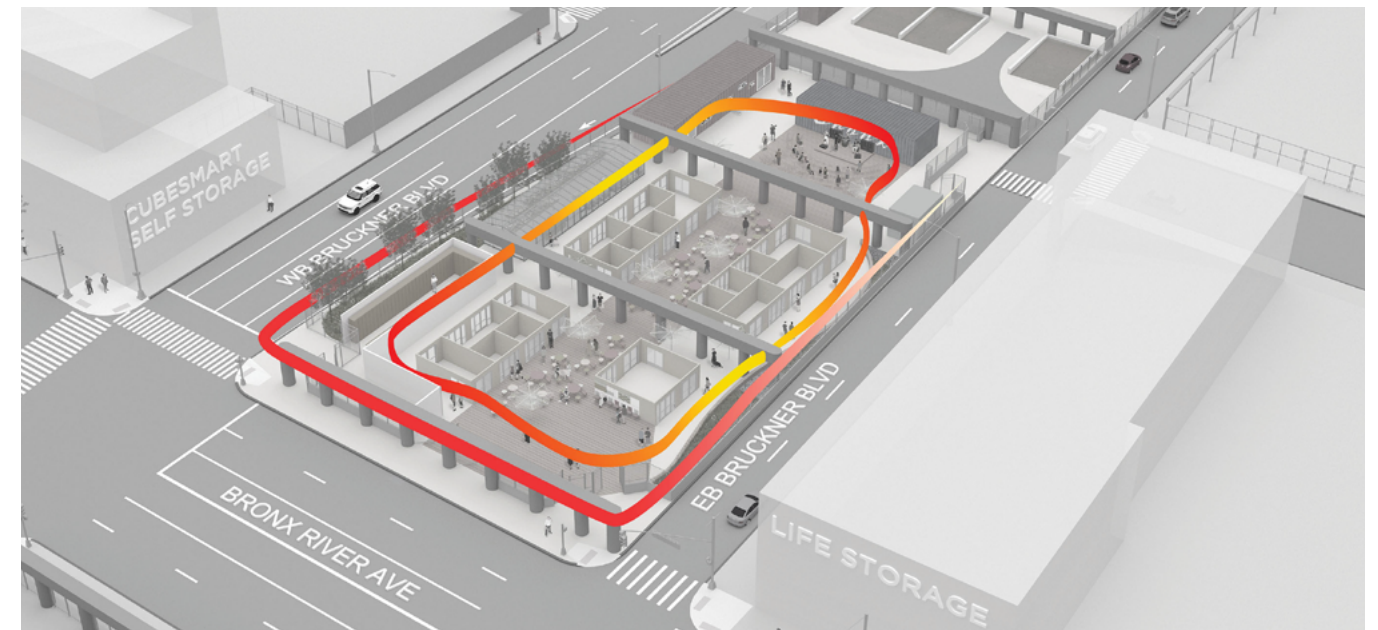

Birds-eye view of architectural metal panels, signs and graphics surrounding the future economic hub.

Overview of the Soundview Economic Hub



Community Classroom
960 SF climate controlled indoor classroom for year-round use.

Performance Space
Large & adaptable event/activity space.

Clean Soil Bank
2000 SF of clean soil storage, loading & unloading activities.

Administrative Offices, Storage & Mechanical Room
Provide space for the administration/operations staff and serves as a backdrop for performance & presentation stage.

Truck/Service Access

Greenhouse
960 SF greenhouse & plant storage area with supplemental grow lights.

Incubator Spaces
Modular units created with Structural Insulated Panels create flexible small-large indoor spaces that are insulated from weather, sound & air-quality concerns.

Last Mile Locker
Secure locker space with a separate entrance allows for neighborhood & on-site delivery exchange.

Lighting
Dispersed tree-like lighting elements provide ample illumination.

Existing Entrance

Enhanced Entrances
Entrances at the North and South Corners of Bronx River Ave. increase public safety by reducing crowding at intersections and accommodate bike racks.

Restroom
Fixed/portable restroom facilities near Close Ave. access point.

Movable Seating
Flexible seating accommodates small-large gatherings for social interaction.

Central Midway
Acts as a primary public active zone.

Information Kiosk
Visitor checkpoint & location for staff to monitor the entrance/exit.

Fixed Seating
Fixed seating lined with permanent plantings is provided on the southern edge of the site where natural light filtration occurs.

Interior Rendering the Soundview Economic Hub



“We need marketing and communications support for tenants and vendors of the space.”

Focus Group Participant

“Open entry-level entrepreneurial opportunities for first-time entrepreneurs and support early-stage enterprises.”

Focus Group Participant

“A central location where revenue, education, or ideas may be shared.”

Focus Group Participant

Share Your Thoughts

3. Is there anything about the proposed designs that surprises you? Why or why not?

.....
.....
.....
.....
.....
.....

.....
.....
.....
.....
.....
.....

4. If you could change or improve one thing about the proposed designs, what would you change and why?



Share your thoughts on the questions above by scanning this QR code or visiting:

bit.ly/SoundviewEconomicHub

Financing

Based on the current design option which includes 2,800 SF of business incubator space, 960 SF of training space, and 960 SF of greenhouse space, and outfitting 16,000 SF of public space with seating, lighting, and placemaking features, the Soundview Economic Hub development is estimated to cost \$6 Million. The calculations below are planning level numbers based on the proposed Conceptual Reuse Plan. Final figures will vary based on the final design, type of construction, quality of fit and finish, and annual escalation.

Construction Costs

Soft Costs

Site Activation/Placemaking	\$125,000
Architectural/Engineering Design Development [Est. 10% Construction Cost]	\$577,500
Construction Administration Services ² [Est. 2-3% Construction Cost]	\$115,500
Operations + Maintenance During Construction [Est. 1-5% Construction Cost]	\$192,500
Builder/Contractor Fee [Est. 10-15% Construction Cost]	\$577,500
Operation and Maintenance During Capital Project [Est. 1 year]	\$482,000
Project Manager	\$80,000
Total Soft Costs	\$2,150,000

Hard Costs

General Conditions/Mobilization	\$350,000
Site Grading, Paving + Hardscaping	\$1,000,000
Utilities	\$600,000
Safety + Security	\$400,000
Lighting + Fans	\$200,000
Site Amenities	\$1,300,000
Total Hard Costs	\$3,850,000
TOTAL CONSTRUCTION COSTS	\$6,000,000

²Services to oversee the construction process and ensure design plans are followed.

Potential Funding Sources*

Pre-Development/Planning

Office of Environmental Remediation	\$25,000
Environmental Protection Agency [Secured]	\$35,000
Total Pre-Development/Planning	\$60,000

Construction

NYC Discretionary Funding - Bronx BP	\$1,000,000
NYC Discretionary Funding - NYC City Council	\$1,000,000
NYS Senate Member Items	\$1,249,250
NYS Assembly Member Items	\$1,249,250
NYC REDC - Empire State Development Grant Funds	\$500,000
NYC REDC - Nonprofit Infrastructure Capital Improvement Program	\$500,000
NEA Grant	\$24,000
Donations / Fundraising	\$417,500
Total Construction	\$5,940,000

TOTAL POTENTIAL FUNDING SOURCES **\$6,000,000**

*Note: The potential funding sources listed represent a combination of opportunities that YMPJ will be pursuing through the remainder of 2023 and 2024. The totals may change as requests are submitted/pending.



South Bronx Context

Soundview is a predominantly Latino community (60%) where majority of households (38%) report living off less than \$25,000 a year. In addition, 6% of individuals are self-employed, over 42% are not a part of the formal economy, and 37% work in the service industry. These are some of the community members the Soundview Economic Hub aims to serve, bringing equitable employment, income, and economic opportunity to the South Bronx.

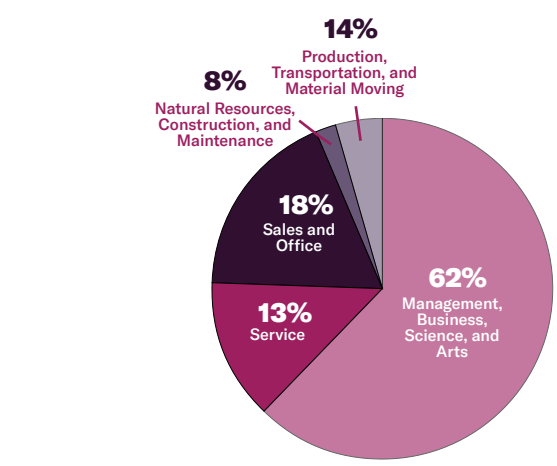
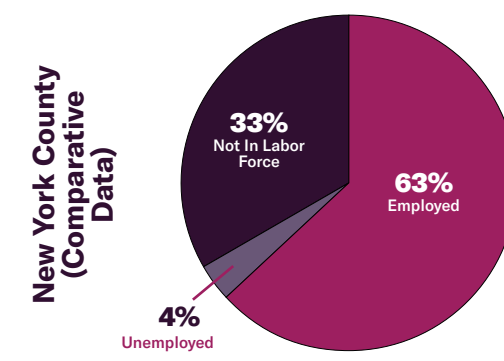
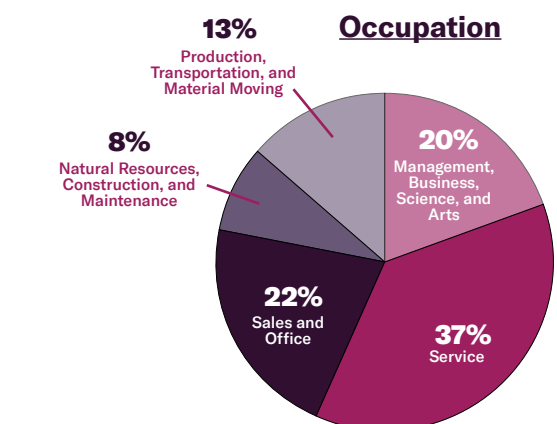
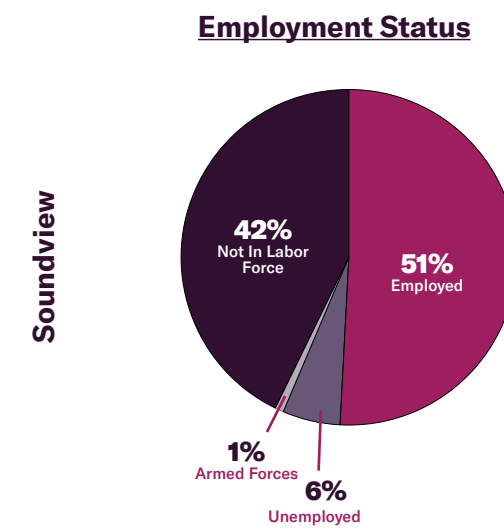
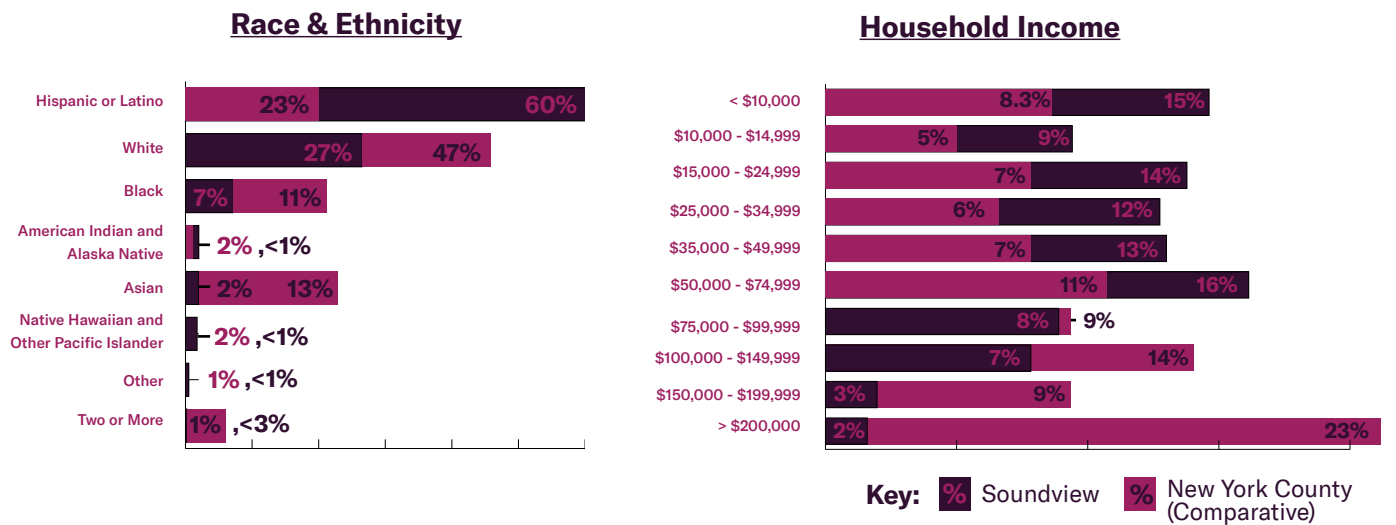

*Data shown gathered from the 2019 American Community Survey, U.S. Census Bureau.

Economic Development Landscape

The Soundview Economic Hub centers community members, local vendors and small businesses in its design, and aims to support ongoing economic development in the South Bronx. Located adjacent to Bruckner Expressway ramps and connected to the Cross-Bronx Expressway, Bronx River Parkway, and other local truck routes - vehicular access presents both a barrier and an opportunity.

The site's proximity to the Hunts Point Markets and recent development such as GrowNYC's Regional Food Hub, an Amazon Warehouse, York Film Studios, and L+M Development Partner's residential towers position it strategically to capitalize on the momentum of development nearby.

The Hub is located at the junction of three neighborhoods and connects nearby Business Improvement Districts and commercial corridors. The relationships and assets outlined below demonstrate how the Soundview Economic Hub can create opportunities that capture local and regional assets, becoming an essential part of the economic development landscape of the South Bronx.

01. Morrison Pubic Plaza and Open Market

Morrison Plaza is a critical food plaza in Soundview that will be transformed into a green-market connecting Soundview to Tri-State Area farmers and local food entrepreneurs as well as provide strategic opportunity for small food business owners.

02. York Studios

The newly constructed Michaelangelo Campus is a 175,000 square foot film and television production campus located in the Soundview neighborhood.

03. Starlight Park

Beginning in the late 1990's, YMPJ partnered with the NYC Parks Department, the NYC Department of Health, Partnership for Parks, The POINT CDC, and the Bronx River Alliance to transform blighted landscapes and contaminated soils along the Bronx River. Starlight Park's remediation and development was part of the initial success of these partnerships.

04. The Bronx River Foodway at Concrete Plant Park

Concrete Plant Park hosts the Bronx River Foodway, a unique community gathering place where organized residents work to enhance local food sovereignty by developing key gardening and food production skills to foster healthy cooking and eating.

As NYC's first ever public foraging site and food forest within a NYC park, it serves as a platform for engaging local residents around food, culture, and health while fostering essential economic development.

05. New and Nearby Housing Developments

Soundview is home to both new and existing housing developments. Large developments include Bronx River Houses, Sotomayor Houses, Monroe Houses, Clason Point Gardens, Lafayette Morrison Houses, Soundview Houses, and the new Soundview Housing Projects - Soundview Family and Soundview Senior.

06. Amazon Warehouse

Part of three sites in the South Bronx, Amazon's new Soundview site is a 205,000 square foot delivery hub at 1055 Bronx River Avenue. This facility significantly increases vehicular and truck traffic in the area.

07. Cass Gilbert Amtrak Station at Westchester Avenue

YMPJ is working to restore the historic, Cass Gilbert-designed Westchester Avenue train station. Rehabilitating the existing station tower, providing a bridge and walkway into Concrete Plant Park, and transforming the existing waiting room into a year round education and event space featuring concession opportunities.

Rendering of Cass Gilbert Amtrak Station at Westchester Avenue



Economic Development Landscape

Key

- 01.** Morrison Plaza and Open Market
- 02.** York Studios
- 03.** Starlight Park
- 04.** The Bronx River Foodway at Concrete Plant Park
- 05.** New and Nearby Housing Developments
- 06.** Amazon Warehouse
- 07.** Cass Gilbert Amtrak Station at Westchester Ave





About YMPJ

YMPJ has focused on activating underutilized public spaces in the South Bronx for more than two decades, successfully bringing more than \$50 million in public investments to improve the Bronx River waterfront. Our urban renewal approach includes both physically reclaiming and activating often blighted spaces, as well as strategies to improve the socio-economic and environmental conditions so critical to the health and stability of our community.

Community Development and Environmental Justice

We work to integrate economic development and environmental justice goals in all of our development projects. Our strategies are as follows:

- **Activation of Underutilized Spaces:**
We have led the remediation and activation of 33 acres of waterfront property, including the cleanup and reclaiming of the Bronx River and the creation of Concrete Plant and Starlight Parks. We are actively programming the Morrison Public Plaza and Open Market at Morrison Ave and Westchester Ave, as well as planning the activation of 30,000 sq ft into the future Soundview Economic Hub.
- **A Focus on Community and Environmental Health:**
We use community organizing, leadership development, coalition building, and data collection to address the environmental and health impacts of decades of structural inequalities, such as toxic pollution and infrastructure divestment. Our campaigns bring together diverse community stakeholders to advocate for policy changes, local investments, and infrastructure projects that reduce truck traffic, improve air quality, increase access to green spaces, and promote access to fresh and healthy foods.
- **Youth Organizing and Leadership Development:**
Our year-round Community Organizing and Leadership Academy (COLA) educates youth on critical issues of inequality, trains them to organize for reform, and provides them with new skills that open up future career paths. COLA fosters opportunities for young people to directly confront the systems of power that impact their daily lives and to push towards ethical and equitable use of urban landscapes. Our model is designed to involve successive generations of community leaders into local initiatives, teach them the history of our environmental justice movement, empower them with the tools and capacity to continue advocating for their communities, and ensure the impact and sustainability of our community development initiatives.

28 Years of Organizing for Community Development and Environmental Justice

1994
YMPJ opens its doors to the Bronx River and Soundview neighborhoods.

2000
YMPJ in collaboration with other South Bronx groups worked with the local Congressman to have the Army Corps of Engineers extract over 40+ submerged cars and thousands of discarded tires and other debris from the Bronx River.



2006
YMPJ organizes local leaders to work with the Pratt Center to develop a conceptual reuse plan for the abandoned Cass Gilbert Amtrak Station on Westchester Ave.

2010
YMPJ organizes to have the Congressman publicly oppose the demolition of the abandoned Cass Gilbert Amtrak Station on Westchester Ave, proposing instead that the centrally located site on the commercial corridor be repurposed for community uses.

1999
YMPJ organizes the cleanup of Starlight Park. \$11 Million is pledged to renovate Starlight Park.

1999
YMPJ leads a rally of over a hundred residents to block the auction of the future site of Concrete Plant Park and submits an alternative use plan to the City of New York.



2001
A coalition of local groups in the South Bronx come together to address air quality by proposing to decommission the Sheridan Expressway to create community development opportunities. The coalition conducts a study demonstrating that the highway is underutilized.

2009
Concrete Plant Park opens 7.39 acres of new waterfront park to the public on a former brownfield that was a contaminated site for over 100 years.

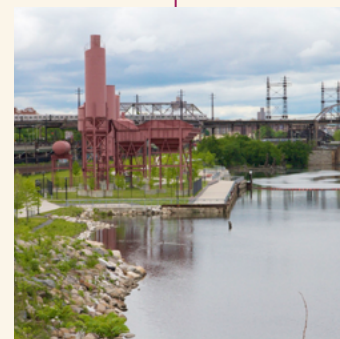

2014
YMPJ launches a community development initiative to transform the Bruckner Expressway underpass at Bronx River Ave into a vibrant community space - the "Soundview Economic Hub", sparking a NYSDOT feasibility study that confirms economic development is possible at the site.

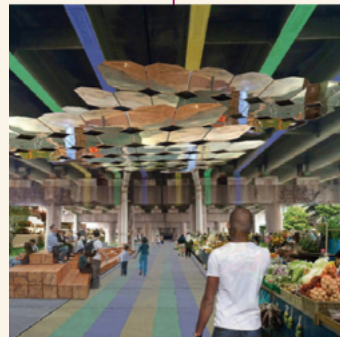

2016
YMPJ works with artists to build "Swale" - a floating food forest on a barge which is docked next to Concrete Plant Park as a statement on the ban on growing food and foraging within Parks.



2020
YMPJ launches a local listening tour during the Covid-19 pandemic as part of the NYS Poverty Reduction Initiative. This process highlighted how communities historically and especially during Covid leveraged underutilized public spaces to meet critical community needs.

2020
YMPJ organizes local stakeholders to secure a \$9M Congressional earmark to transform abandoned public spaces into a 2500sf public plaza, kiosk, and seasonal market at the intersection of Westchester Ave and Morrison Ave and along Harrod Place.

2017
YMPJ partners with NYC Department of Parks and Recreation to launch NYC's first food forest, the Bronx River Foodway at Concrete Plant Park.

2017
In response to almost 20 years of advocacy from YMPJ and other local groups, NYSDOT commits \$1.8B to route trucks off local streets and directly into the Hunts Point Market as part of the Sheridan Expressway redevelopment. Construction is projected to conclude by 2030.

2022
Morrison Plaza and Open Market opens to the community, bringing healthy food and programming to the commercial corridor.

2022
NYSDOT begins construction of the Soundview Economic Hub in preparation for turning over to YMPJ in 2023.

2021
YMPJ develops a conceptual reuse plan for the Soundview Economic Hub with technical assistance from the EPA.

2021
YMPJ launches NYC Communities Activating Public Spaces (NYC-CAPS) - a citywide coalition with the goal of removing barriers communities face in activating underutilized public spaces. This budding collective impact coalition is a model for addressing health, equity, and resiliency that is recognized by a North American competition - the Thriving Cities prize.

2022
YMPJ leads the NYC-CAPS coalition in issuing a report that outlines precedents and policy recommendations for communities to reclaim and activate underutilized public spaces. The report is produced in collaboration with grassroots partners citywide, including Hester Street and various city agencies.

2022
YMPJ organizes a coalition of local groups to work with consultants to develop a roadmap for redeveloping the Cass Gilbert Amtrak Station on Westchester Ave. The EPA-funded roadmap incorporates conceptual reuse and engineering studies, and is featured in the NY Times. Congressman Torres pledges support after touring the site.

Moving Forward

As YMPJ and its partners move toward implementation, YMPJ is seeking the following: (i) support funding the development, design, and construction process; (ii) support funding programs and leveraging public and private funds for annual operating costs related to running programs; and (iii) support with program innovation, implementation and expansion for the Soundview Economic Hub.

Site Access and Control

In order to secure control of the site and begin construction, YMPJ will need to meet New York State Department of Transportation's (NYSDOT) property management requirements and receive formal approval for the project from the Federal Highway Administration (FHA). Part of this process will require YMPJ to obtain a Use and Occupancy Permit along with the appropriate insurance coverage. In 2022, YMPJ will share the latest proposed Conceptual Reuse Plan for the Bruckner Expressway Underpass at Bronx River Ave with NYSDOT, and begin filing for FHA approval before starting construction to outfit the space. Once the construction process is complete, YMPJ and the future operational partners of the Soundview Economic Hub will be responsible for the programming, operation, grounds maintenance and cleanup on the site. The estimated implementation process is outlined in the diagram below.

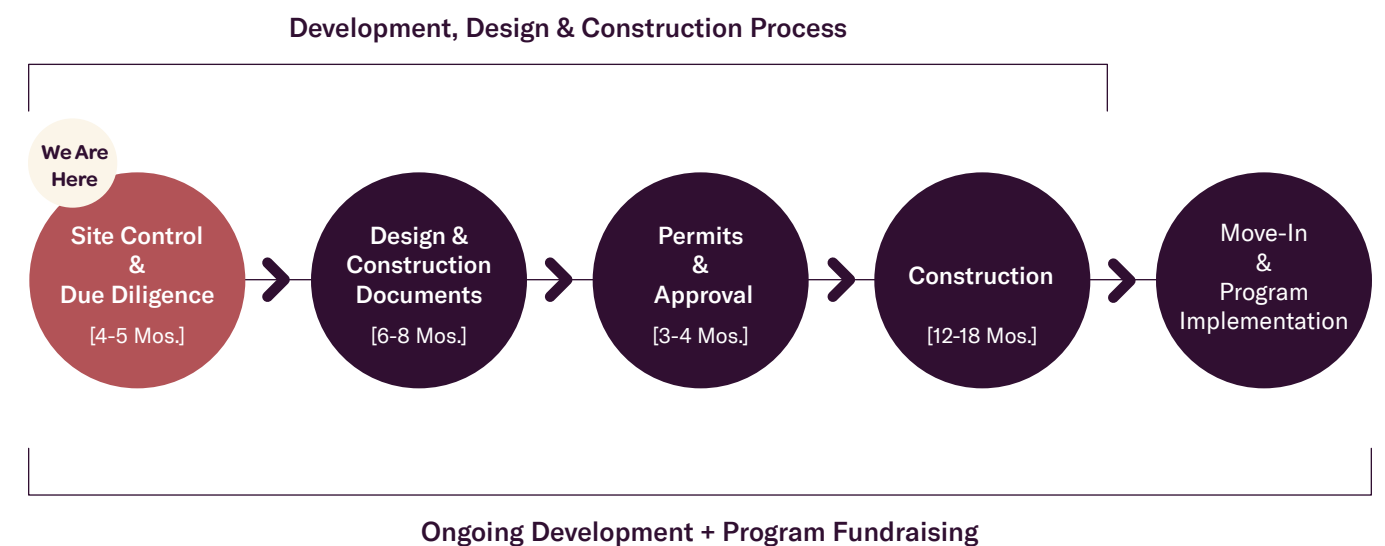

Share Your Thoughts



5. What new or existing opportunities do you see to partner with YMPJ on the Soundview Economic Hub?



Share your thoughts on the questions above by scanning this QR code or visiting:

bit.ly/SoundviewEconomicHub

Appendix

1 Case Studies	Page 40
2 Sip Panel System	Page 42
3 Air Flow and Climate Control	Page 43
4 Utility Connection Diagram	Page 44

Case Studies

Cities across the country are successfully transforming abandoned and underutilized underpasses into public community assets. These projects demonstrate the variety of activities that can be housed within an underpass and serve as an inspiration for the programs and activities proposed for the Soundview Economic Hub.



1. Pedestrian Plaza

East Harlem, NY

Pedestrian plaza under the elevated Metro-North railroad tracks. The space has been used as a mobile vaccination and food distribution site.

2. La Marqueta

East Harlem, NY

Market place under the elevated Metro-North railroad tracks. The space includes on-site baking facilities and an urban gardening center.

3. Urban Garden Center

East Harlem, NY

22,000 SF outdoor garden center located on East 116th Street and Park Avenue under the Metro North railroad tracks. The space uses environmentally responsible methods to run the garden center.

4. Claiborne Innovation District

New Orleans, LA

19-block space beneath the elevated expressway along Claiborne Avenue. The market space and CID will include classrooms, exhibit space, technology and education demonstrations, youth programming, workshops, etc.

5. Underground Boston

Boston, MA

8-acre underpass park between Boston's South End and South Boston. The park features pedestrian boardwalks, bicycle paths, and a dog park.

6. Underpass Park

Toronto, Ontario

Located beneath a series of overpasses in Toronto's downtown. The park features flexible community spaces for children and adults, including a playground, basketball courts and a skate park.

7. Parasite Skate Park

Location: New Orleans, LA

Located at the intersection of I-610 and Paris Avenue. The space is a community-led do-it-yourself public park that has become the area's first official skate park.

8. The Underline

Miami, FL

10-mile linear park under Miami's Metrorail. The park will feature an urban trail and public art destination that includes an outdoor gym complex, community gathering spaces, gardens and meditative spaces.

Sip Panel System

The enclosed spaces within the Soundview Economic Hub will be constructed using prefabricated Structural Insulated Panels (SIPs) due to their structural integrity, ease of installation, and ability to be reconfigured as the needs and uses of the site change over time. The panels will be joined together to create spaces such as in the example below. These spaces will be independent of the highway structure and ensure that the Department of Transportation has continued access to the highway for maintenance and repairs.



Air Flow and Climate Control

The installation of commercial grade ceiling fans and ductless heat pump systems for the indoor spaces will ensure enhanced air movement and climate control. Mini-Split Heat Pumps, such as in the example below, would be mounted on the walls of the interior spaces to provide heating and cooling.

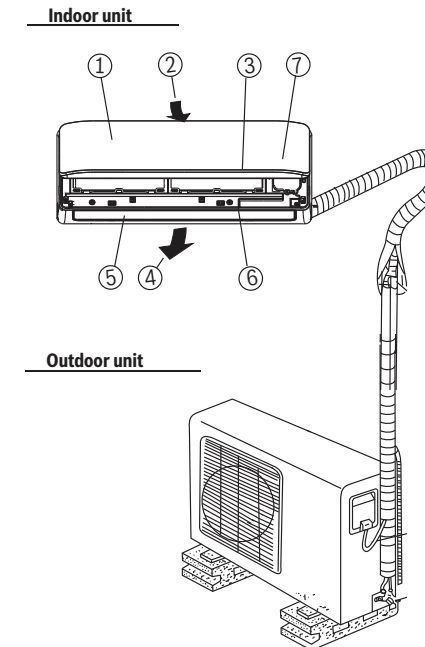

Example of Bosch Climate Mini Split for Climate Control

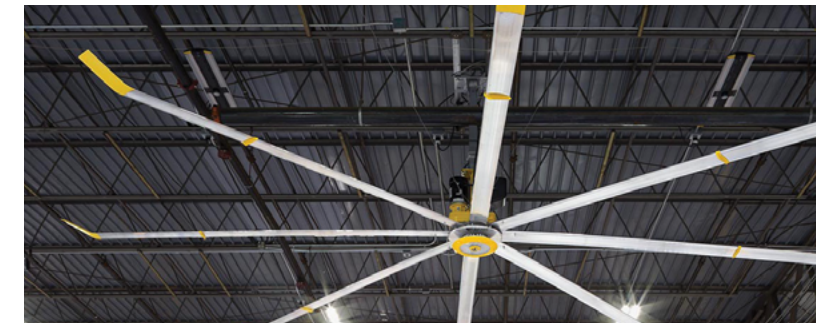

Example of commercial grade ceiling fan

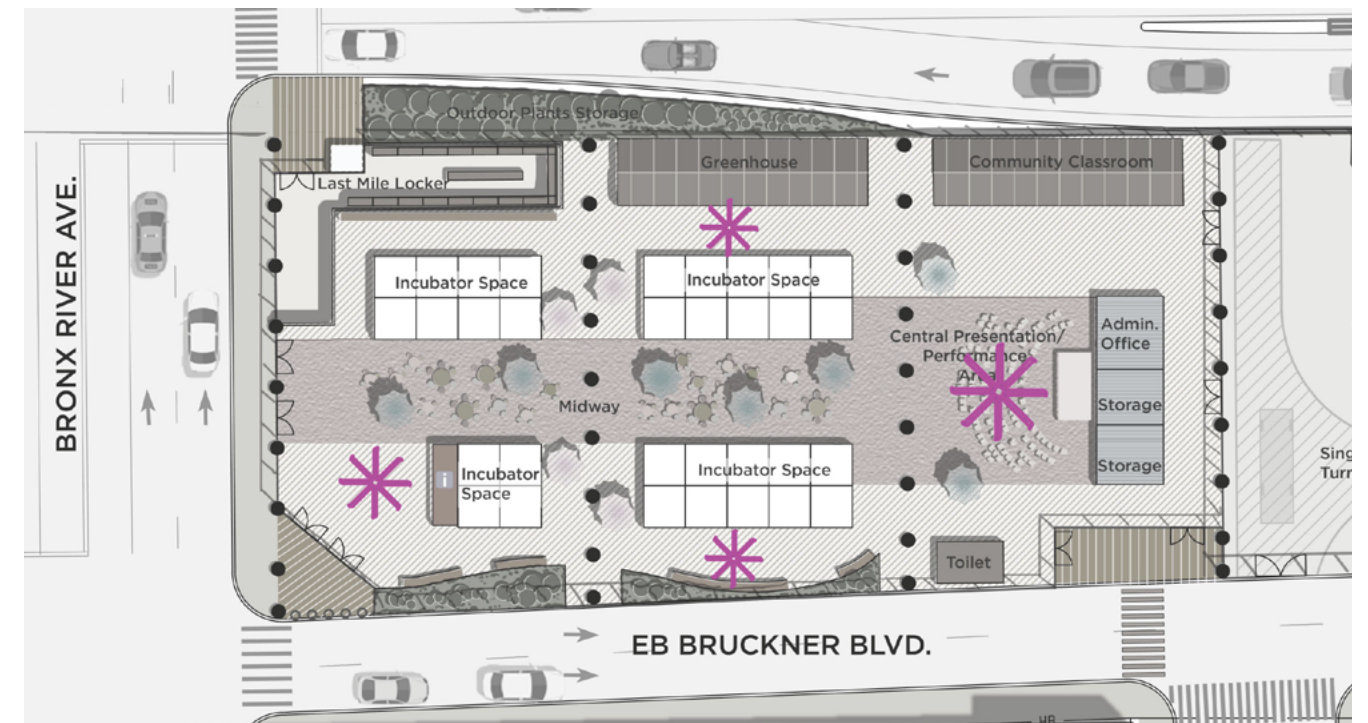

Layout of proposed commercial grade ceiling fans

Utility Connection Diagram

While standard under-bridge lighting will be included in the site as part of the on-going renovation, some additional utility connections are recommended for the site to function as an economic hub. These additional proposed utilities would enter the site from the eastbound Bruckner Boulevard in the vicinity of Close Avenue to maximize efficiency and easy access for future servicing. This strategy also includes a uniformly spaced grid of wet and dry services underground to allow flexibility for the potential site configurations, duct banks to provide additional separated capacity for coolant exchange lines to support the use of ductless mini-split HVAC units within the modular building units, and at-grade storm drains installed at regular intervals to allow for cleaning the space.

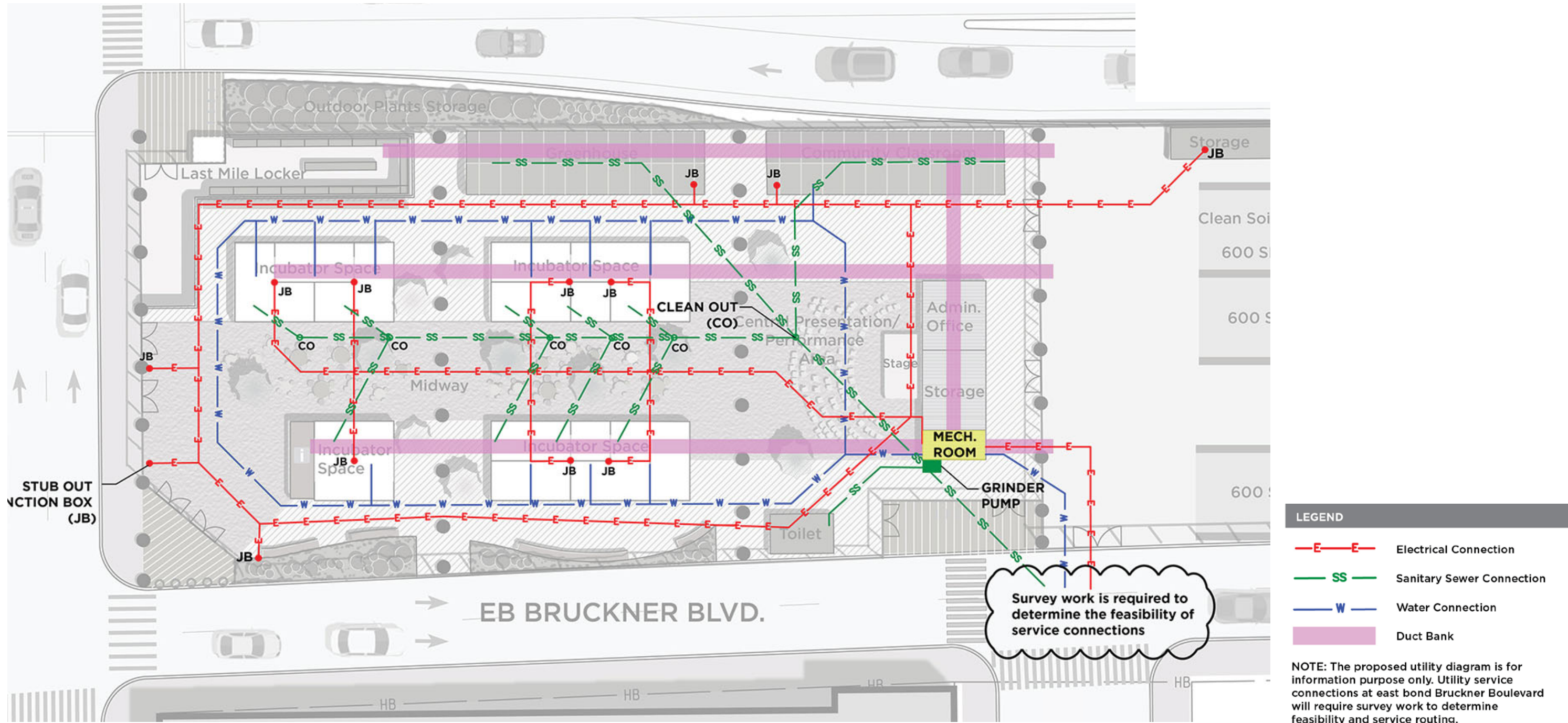

Acknowledgments

This community engagement and development planning process has been an initiative of Youth Ministries for Peace and Justice, Inc (YMPJ) in partnership with other community stakeholders and with the support of the US Environmental Protection Agency (EPA), Mayor’s Office of Environmental Remediation, the NYC Small Business Services, the NYC Economic Development Corporation, and the NY State Department of Transportation. Critical technical support by Stromberg/Garrigan & Associates, Inc (SG-A), ICF Incorporated, Hester Street, and other key advisors has been critical to moving from vision to reality.

We would like to thank all those who continue to make our work activating people and places possible, including our elected officials and community partners. We also thank those that will be most impacted by what we do, the many South Bronx residents whose passion and commitment to transforming this space under the highway into the future Soundview Economic Hub inspires us.

We thank the following individuals and entities for sharing their insight, support, time, and expertise to inform the development of the future Soundview Economic Hub:

Technical Advisors

Kevin Palaia, ICF Incorporated

Amanda Schachter, SLO
Architecture

Chris Anderson

Emily Blanton, ICF Incorporated

Kristen Chin, Hester Street

Sean Garrigan, Stromberg/
Garrigan & Associates, Inc.

Andrew Harris, Hester Street

Feifei Huang, Stromberg/
Garrigan & Associates, Inc.

Maggie Irwin, ICF Incorporated

Kim Ochilo, Hester Street

Supporters

Schenine Mitchell, US
Environmental Protection
Agency

Aimee Storm, US Environmental
Protection Agency

Sahar Rana, US Environmental
Protection Agency

Mark McIntyre, Mayor’s Office
of Environmental Remediation

New York State Department of
Transportation

New York City Small Business
Services

New York City Economic
Development Corporation

New York City Department of
Transportation

Assembly Member Kenny
Burgos, NYS Assembly

Assembly Member Amanda
Septimo, NYS Assembly

Council Member Ruben Diaz,
Sr., NYC Council

Council Member Rafael
Salamanca, NYC Council

Concrete Friends

Friends of Soundview Park

Maggie Greenfield, Bronx River
Alliance

Kelly Moltzen, Bronx Health
Reach

Kerry McLean, WHEDCo

Paul Lipson, Barretto Bay
Strategies

Michael Hurwitz

Marcos Crespo, Montefiore

Deutsche Bank

L+M Developers

Steve Flax, M&T Bank



Youth Ministries for Peace and Justice

1384 Stratford Ave
Bronx, NY 10472-1604

Website: <https://www.ympj.org/>
E-mail: news@ympj.org
Phone: (718) 328-5622

